

Universal Field Controller to individually control up to 2 motorized fire or smoke extraction dampers. It is the perfect solution for bus (Modbus and BACnet) or conventional integration into a superior system.



Content

Section	Page	Section (continuation)	Page
Technical Data	1	Connection Details	11
Cable Specification	4	Conventional Application	12
Dimensions	5	Explanation of LEDs	13
Removing the Cover of the Housing	6	Functionality of Test Buttons	14
Electrical Installation	7	Run Time Monitoring of Actuator	15
Power Supply	8	Full Auto Test	15
Modbus and BACnet Addressing	9	Bus Monitoring Application	16
Configuration through Dip Switch	10		

Technical Data

Electrical Data	Nominal Voltage	24 V AC / DC
	Nominal Voltage Range	-20%... + 20%
	Dimensioning	2 VA + damper actuators (max. 24 VA)
	Power Consumption	2 W + damper actuators
	Connections	AMP plug-in connections and quick connections (terminals)

Communication / Modbus



Protocol	Modbus RTU
Medium	RS-485, not electrically isolated
Transmission Formats	Specified by Modbus RTU Standards
Number of Devices per Line	100 (without repeater)
Baud Rates	9'600, 19'200 bps
Address	1..127 (0 reserved for broadcast)
Termination	120Ω line termination. Jumper available on extra pin on PCB. Position of jumper if FSC-UFC24-2 is last Modbus device in line, see electrical installation, page 7
Typical Response Time	<200 ms

	Integration / Modbus Register	We refer to the detailed Modbus register of the FSC-UFC24-2. Available under www.smtec-ag.ch/en/products
 <p>Communication / BACnet</p>	Protocol	BACnet MS/TP
	Medium	RS-485, not electrically isolated
	Number of Devices per Line	65 (without repeater)
	Baud Rates	9'600, 19'200, 38'400, 76'800 bps (auto detect)
	Address	1..127 (0 reserved for broadcast)
	Termination	120Ω line termination. Jumper available on extra pin on PCB. Position of jumper if FSC-UFC24-2 is last BACnet device in line, see electrical installation, page 7
	Typical Response Time	<100 ms
	Device Instant	Automatically assigned by physical address, writable
	Integration / BACnet Objects, Pics	We refer to the detailed BACnet objects, pics of the FSC-UFC24-2. Available under www.smtec-ag.ch/en/products
	<p>Safety</p>	Protection Class
Protection Degree		IP42, housing of non-flammable polycarbonate
Electromagnetic Tolerance		CE in accordance with 2004/108/EC
Low Voltage Directive		CE in accordance with 2006/95/EC
Mode of Operation		Type 1 (EN 60730-1)
Rated Impulse Voltage		2.5 kV (EN 60730-1)
Degree of Pollution of Environment		2 (EN 60730-1)
Ambient Temperature		-20° C to + 50 °C
Storage Temperature		-20° C to + 80 °C
Humidity Test		95% RH, non-condensing (EN 60730-1)
Maintenance	Maintenance free	
<p>Mechanical Data (Dimensions / Weight)</p>	Width	120 mm
	Length	153 mm
	Height	57 mm (with bracket)
	Weight	ca. 445 g (with bracket)
	<i>See drawings page 5</i>	

Installation The FSC-UFC24-2 is directly installed at or close to the fire or smoke extraction damper. The bracket can be pre-installed. The FSC-UFC24-2 can be snapped onto the bracket any time (at the damper manufacturer or at the job site).

Electrical Installation See details page 7.

Safety Notes The FSC-UFC24-2 is not allowed to be used outside the specified field of application, especially in aircraft or in any other airborne means of transport.
The company buying and / or mounting the FSC-UFC24-2 on site bears full responsibility for the proper functioning of the whole system. Only authorized specialists may carry out the installation. All applicable legal or institutional installation regulations must be complied with during installation.
The device contains electrical and electronic components and is not allowed to be disposed of as domestic refuse. All locally valid regulations and requirements must be observed.

Product Features / Application The FSC-UFC24-2 is used together with one or two fire or smoke extraction damper actuators to individually control and monitor one or two fire or smoke extraction dampers. This Universal Field Controller has one bus address which offers individual control and status messages for each of the two connected actuators. It provides Modbus, BACnet or conventional connection and is normally mounted at or close to the damper.

Following control modes can be chosen through dip switch terminal:

- Fire or smoke extraction application
- Bus protocols: Modbus or BACnet

Conventional: Digital input per damper for conventional application.

These digital inputs for the conventional application in the FSC-UFC24-2 always override the bus commands.

Universal System Link between one or two fire or smoke extraction dampers and any Modbus or BACnet system or conventional control.

Power Supply The FSC-UFC24-2 needs to be powered up with 24 V AC / DC. The FSC-UFC24-2 provides the power supply to the actuators. For more details see page 8.

Control *Conventional*

The FSC-UFC24-2 offers the option to work without bus communication (Modbus / BACnet) and can be controlled in a conventional way. There is one input for each damper to open or close the dampers. The home position is depending on the fire or smoke extraction application. It is also possible to monitor the damper position conventional through a digital output signal.

Communication *Serial Communication – RS-485*

Through Modbus RTU (RS-485) or BACnet MS/TP (RS-485). We refer to the detailed information in the Modbus register / BACnet object list / pics of the FSC-UFC24-2. Available under www.smtec-ag.ch/en/products.

Actuator Connection

3-pole AMP plug and terminal connections for 2 standard 24 V AC/DC fire or smoke extraction actuators.
6-pole AMP plug and terminal connections for 2 internal actuator end switches each. Identification of the end position switches of the actuators.

Additional Connections

2-pole terminal connections for digital inputs (potential free contact) for conventional application.

Cable Specification



120 Ω with 1 Mhz. Made of 24# flexible twisted pairs overall foil + braidshielded and overall jacketed with a flexible compound for indoor use, or similar. Cable type: Belden 3105a or equivalent.

IMPORTANT: SMT takes no responsibility of the functionality of the units / network if a different cable is used to the one specified here.

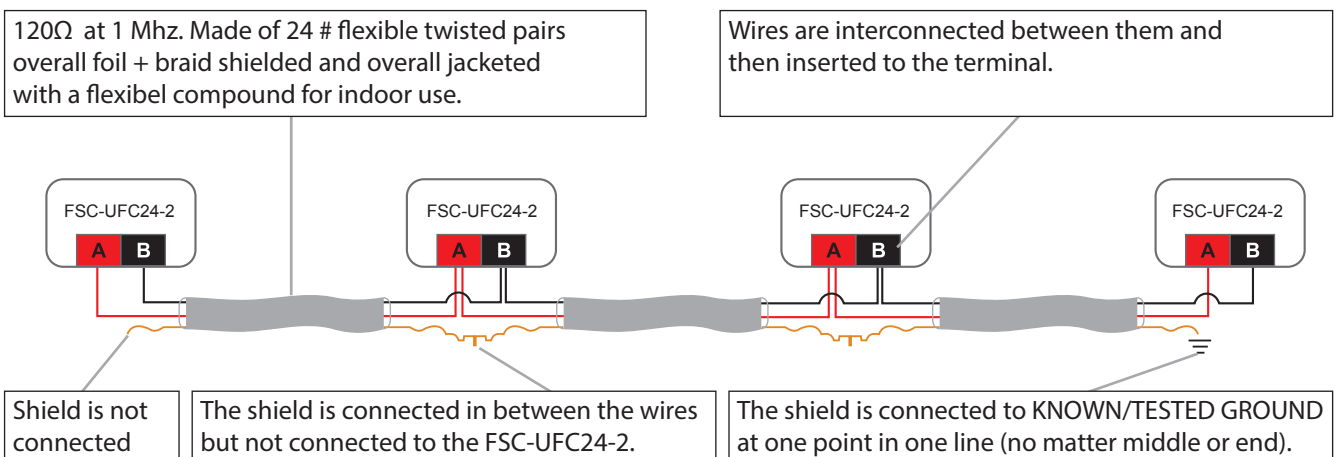

← Up to 1'200 meters and max. 100 FSC-UFC24-2 with Modbus RTU and 65 FSC-UFC24-2 with BACnet MS/TP →

Dimensions

FSC-UFC24-2



Mounting Bracket

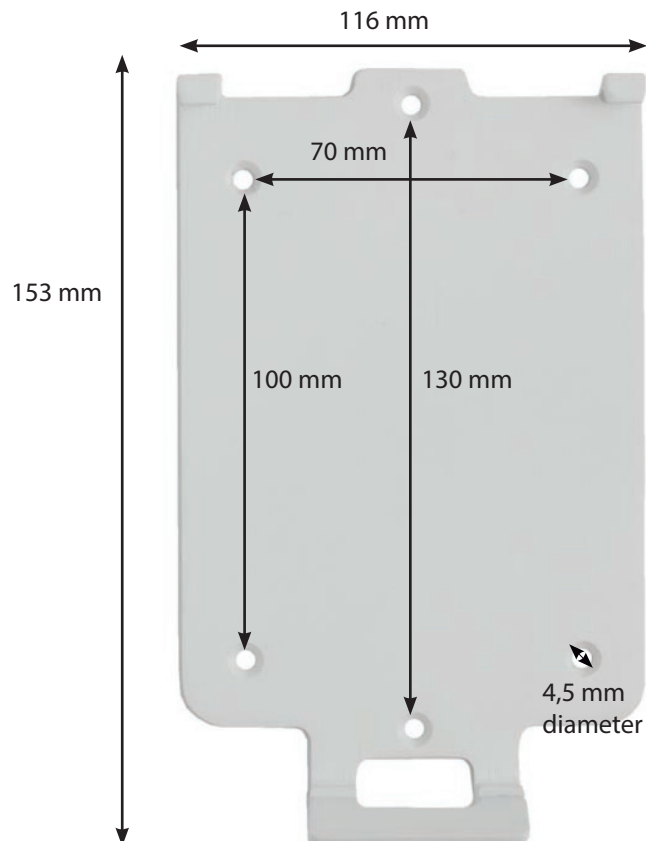

Removing the Cover of the Housing

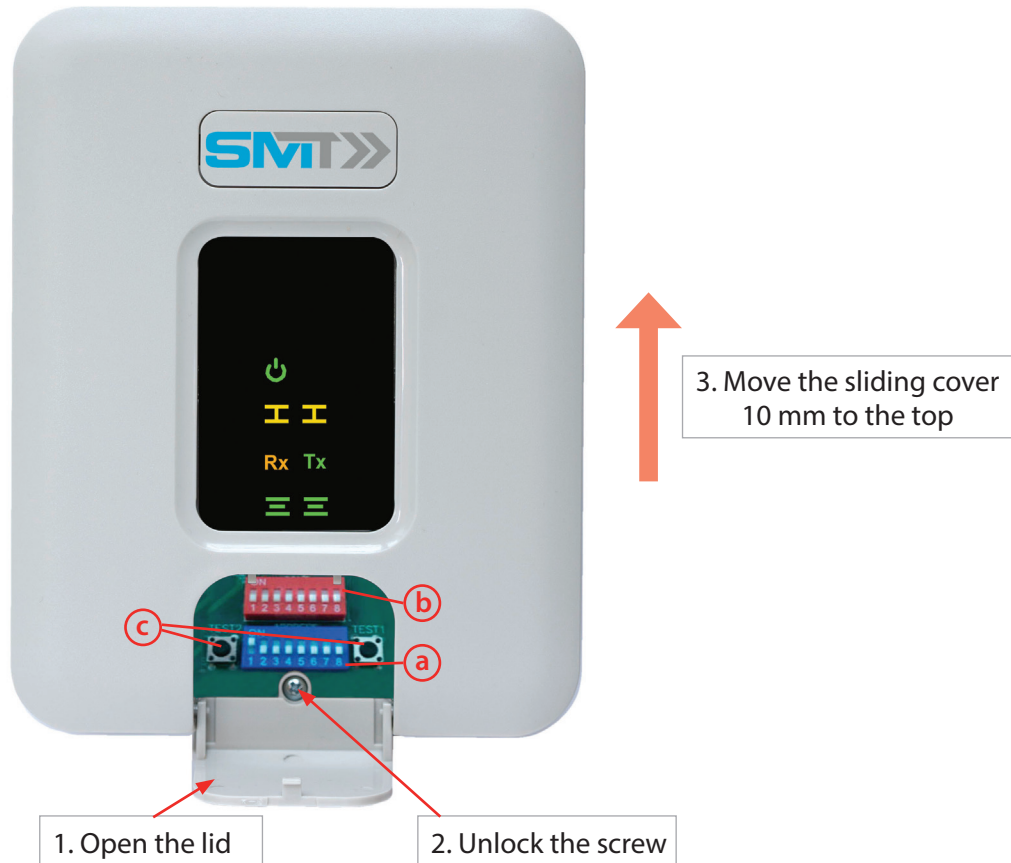

1. Open the small lid on the lower end of the housing by flapping up the cover
2. Unlock the screw which is placed on the lower end in the middle
3. Move the sliding cover 10 mm to the top
4. Remove the cover

Lid for Easy Access to Dip Switch Terminals (Configuration / Addressing) and Test Button

- (a)** The blue coloured dip switch terminal is for the Modbus or BACnet addressing.
- (b)** The red one for the configuration.
- (c)** Test buttons: For detailed explanation of the function of the test button see page 14.

Electrical Installation

General Information

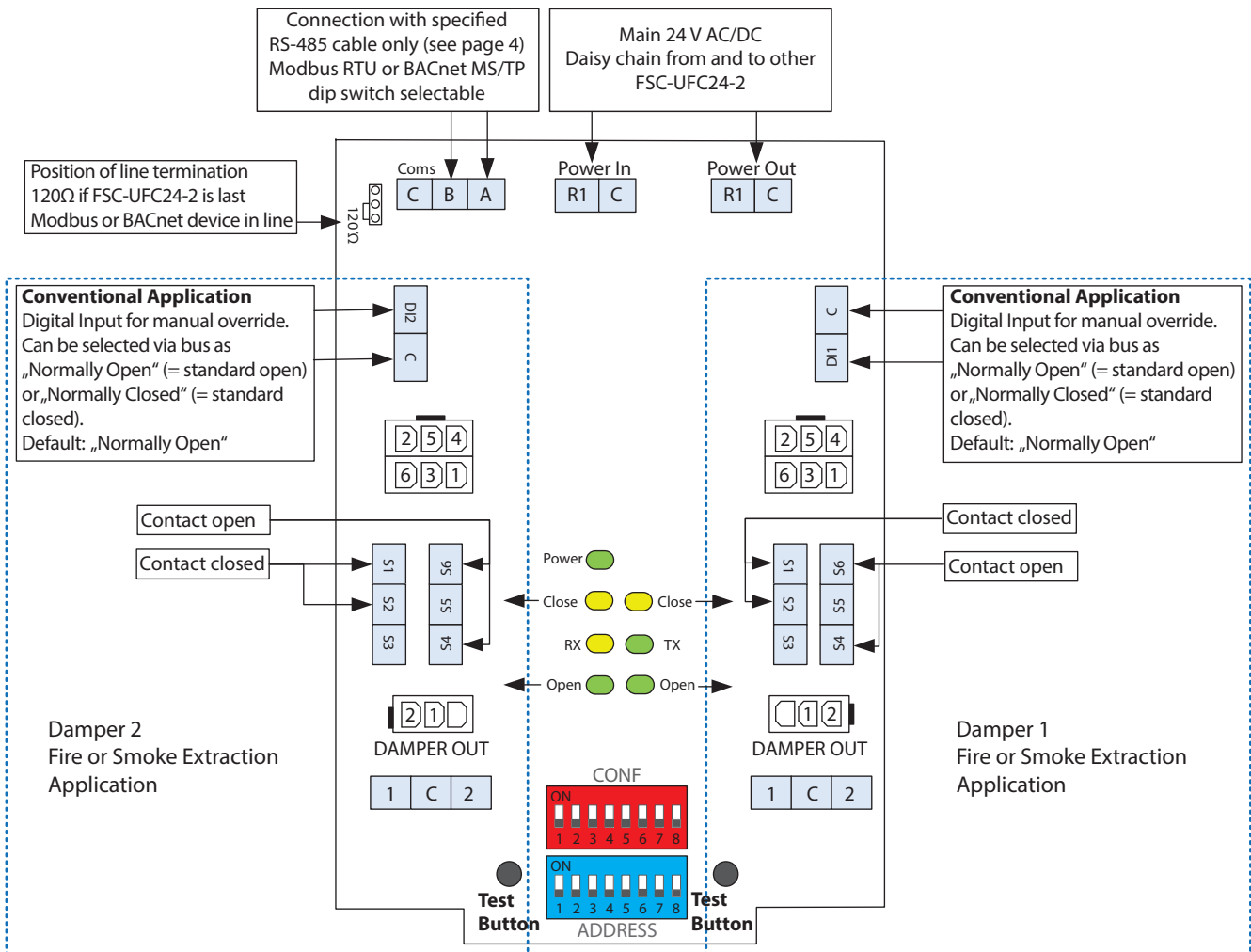

Hybrid forms (fire and smoke extraction actuator) are possible.

IMPORTANT:

If only one actuator is connected to the FSC-UFC24-2 the LEDs of the side where no actuator is connected indicate an alarm. A jumper has to be installed between S4 and S6 in the terminal where there is no actuator connected, to indicate an "opened" position in the LED. If the second connection is not activated via bus, there will be no alarm signal on the bus system.

Power Supply

Main Power – FSC-UFC24-2

The FSC-UFC24-2 is dual power 24V AC/DC.

The fire damper or smoke extraction actuator has to be 24V AC and/or DC. Meaning the actuator has to operate with the same voltage (AC or DC) as the FSC-UFC24-2. There are 2 terminals available for the power supply, in order to make the daisy chain connection for the installer easier.



The polarity must be respected when connecting multiple FSC-UFC24-2 to one power source (phase to phase, com to com)!

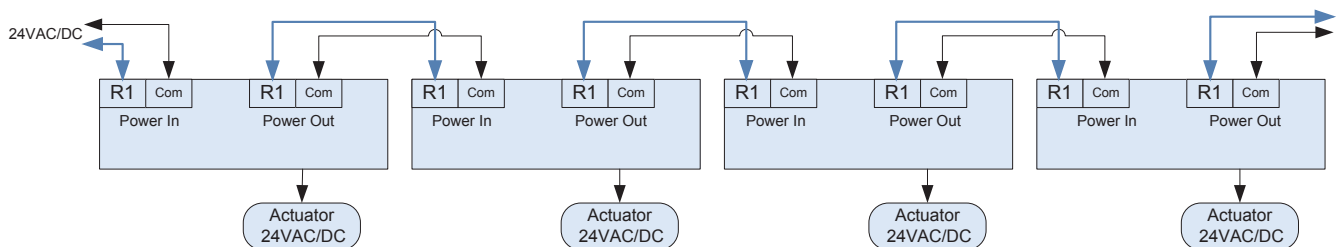

Modbus and BACnet Addressing

If the FSC-UFC24-2 is used in combination with the Controllers of SMT (FSC-M30, FSC-M240, FSC-M240-MX), the addressing is recommended to be done in consecutive order. Dip switch 8 not in use.

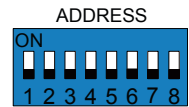

Address	Switches On	Address	Switches On	Address	Switches On	Address	Switches On
0*	Broadcast-not in use	33	1+6	66	2+7	99	1+2+6+7
1*	1	34	2+6	67	1+2+7	100	3+6+7
2*	2	35	1+2+6	68	3+7	101	1+3+6+7
3*	1+2	36	3+6	69	1+3+7	102	2+3+6+7
4*	3	37	1+3+6	70	2+3+7	103	1+2+3+6+7
5*	1+3	38	2+3+6	71	1+2+3+7	104	4+6+7
6*	2+3	39	1+2+3+6	72	4+7	105	1+4+6+7
7*	1+2+3	40	4+6	73	1+4+7	106	2+4+6+7
8*	4	41	1+4+6	74	2+4+7	107	1+2+4+6+7
9*	1+4	42	2+4+6	75	1+2+4+7	108	3+4+6+7
10*	2+4	43	1+2+4+6	76	3+4+7	109	1+3+4+6+7
11	1+2+4	44	3+4+6	77	1+3+4+7	110	2+3+4+6+7
12	3+4	45	1+3+4+6	78	2+3+4+7	111	1+2+3+4+6+7
13	1+3+4	46	2+3+4+6	79	1+2+3+4+7	112	5+6+7
14	2+3+4	47	1+2+3+4+6	80	5+7	113	1+5+6+7
15	1+2+3+4	48	5+6	81	1+5+7	114	2+5+6+7
16	5	49	1+5+6	82	2+5+7	115	1+2+5+6+7
17	1+5	50	2+5+6	83	1+2+5+7	116	3+5+6+7
18	2+5	51	1+2+5+6	84	3+5+7	117	1+3+5+6+7
19	1+2+5	52	3+5+6	85	1+3+5+7	118	2+3+5+6+7
20	3+5	53	1+3+5+6	86	2+3+5+7	119	1+2+3+5+6+7
21	1+3+5	54	2+3+5+6	87	1+2+3+5+7	120	4+5+6+7
22	2+3+5	55	1+2+3+5+6	88	4+5+7	121	1+4+5+6+7
23	1+2+3+5	56	4+5+6	89	1+4+5+7	122	2+4+5+6+7
24	4+5	57	1+4+5+6	90	2+4+5+7	123	1+2+4+5+6+7
25	1+4+5	58	2+4+5+6	91	1+2+4+5+7	124	3+4+5+6+7
26	2+4+5	59	1+2+4+5+6	92	3+4+5+7	125	1+3+4+5+6+7
27	1+2+4+5	60	3+4+5+6	93	1+3+4+5+7	126	2+3+4+5+6+7
28	3+4+5	61	1+3+4+5+6	94	2+3+4+5+7	127	Reserved factory defaults
29	1+3+4+5	62	2+3+4+5+6	95	1+2+3+4+5+7		
30	2+3+4+5	63	1+2+3+4+5+6	96	6+7		
31	1+2+3+4+5	64	7	97	1+6+7		
32	6	65	1+7	98	2+6+7		

Via each, per dip switch allocated Modbus or BACnet address, the second actuator can be individually controlled through the software (see Modbus Register or BACnet Object List).

Configuration through Dip Switch

Default Dip Switch Position

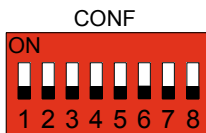

Configuration Possibilities

Pin	Off (Default)	On
1	Fire Damper 1	Smoke Extraction Damper 1
2	Fire Damper 2	Smoke Extraction Damper 2
3	Modbus RTU	BACnet MS/TP
4	Baud Rate (Off-Default)	
5	Parity (Modbus only)	None Parity (Modbus only)
6	Not In Use=Off	
7	Not In Use=Off	
8	Not In Use=Off	

Information Pin 1 and 2:

If Pin 1 or 2 are changed from fire to smoke extraction application or from smoke extraction to fire application, the FSC-UFC24-2 needs to be taken off the power supply and put back again to activate the new mode.

Information Pin 3:

When a FSC-UFC24-2 has been connected and operated in one bus protocol first (Modbus or BACnet) and then will be operated by the other (BACnet or Modbus) the factory reset functionality in the FSC-UFC24-2 MUST be activated by bus communication as soon as it is connected to the other protocol (Modbus register 27, BACnet Object List BV 18). **If the FSC-UFC24-2 is used in connection with the Controllers of SMT (FSC-M30, FSC-M240, FSC-M240-MX), Pin 3 has to be on ON (BACnet).**

Baud Rate Selection Modbus

This has to be done when choosing Modbus only.
Single Writing!

	9600 (Default)	19200
4	Off	On

Baud Rate Selection BACnet

Baud rate in BACnet is automatically detected.
Single Writing!

Connection Details

Fire Damper Actuator (spring return) – Connections

When the actuator has power the fire damper is open. When there is no power, the actuator closes the fire damper with the integrated spring.

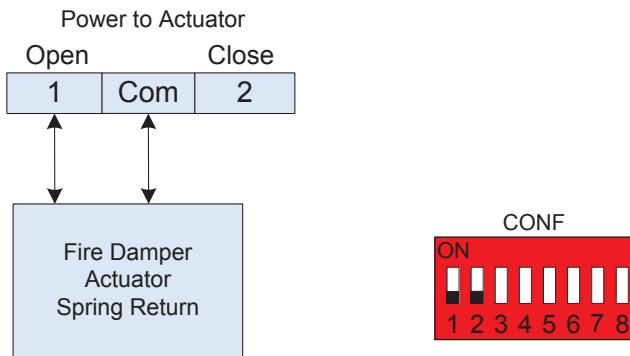

Smoke Extraction Damper Actuator – Connection

If the actuator is powered up the smoke extraction damper is either open or closed.

If the FSC-UFC24-2 sends the smoke extraction damper actuator the open signal, pin OPEN is powered. If the FSC-UFC24-2 sends the smoke extraction damper actuator the close signal, pin CLOSE is powered.

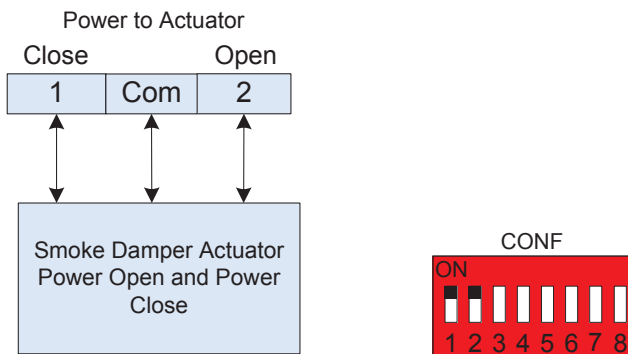

Fire Damper

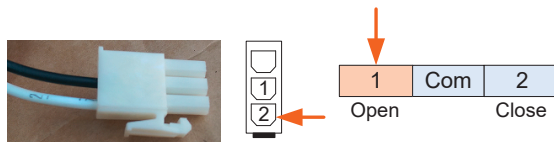

When the FSC-UFC24-2 is powered up, the power to the actuator is on output 'open' (pin nr 1).

Smoke Extraction Damper

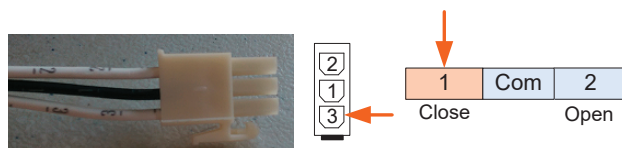

On power up the CLOSE output will be ON. During normal operation the FSC-UFC24-2 will hold the last command on memory. Only valid for the smoke extraction application.

After Connection - Power Reset:

- **Fire Damper Application** will always go to OPEN.
- **Smoke Extraction Damper Application** will hold last command on memory.

Conventional Application

If the bus is not connected, the FSC-UFC24-2 can be controlled conventionally. No configuration settings are necessary in this case. One digital input for the conventional application is available for each of the two dampers. This digital input is used to open or close the damper. Digital output signals indicate the actuator position.

Digital Input: volt free, normally open as default (can be changed on bus).
The digital input allows to control the damper position through an external contact/device.

These digital inputs for the conventional application in the FSC-UFC24-2 always override the bus commands.

Digital Output: The feedback signals (on/off) of the actuator can be forwarded via the connections S1 and S2 (actuator/damper closed) and / or S4 and S6 (actuator/damper open) to any control or monitoring device.

These outputs can be connected in parallel between the different FSC-UFC24-2 to monitor their status.

Current output max is 5mA.

Electrical Installation for Conventional Application

Feedback signals from the FSC-UFC24-2:

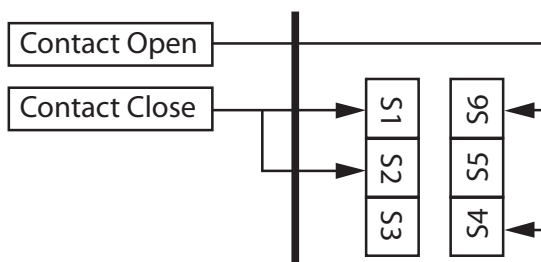







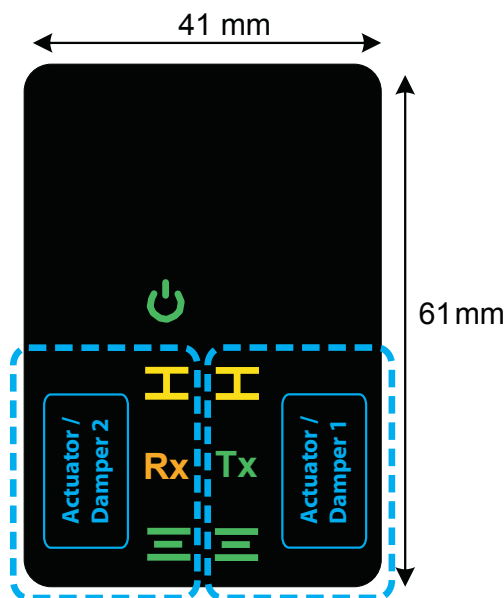

Explanation of LEDs

The LEDs are only visible if they are active. If not active the symbols will not appear.

IMPORTANT:

If only one actuator is connected to the FSC-UFC24-2 the LEDs of the side where no actuator is connected indicate an alarm. A jumper has to be installed between S4 and S6 in the terminal where there is no actuator connected, to indicate an "opened" position in the LED. If the second connection is not activated via bus, there will be no alarm signal on the bus system.



Led	Color	Action	Description
Power	 Green	On	Power is connected
Alarm	 Yellow and green per actuator / dampers blinking alternately	Flash Interval 0.5 sec	Actuator did not reach end switch position within set time
Alarm	 Yellow and green per actuator / dampers blinking alternately	Flash Interval 3 sec	Alarm active at damper(s); bus command = actuator open, actuator = in closed position
Rx	 Yellow	Flash	Receive data
Tx	 Green	Flash	Transmit data
Close	 Yellow	On	Damper close
Open	 Green	On	Damper open
Close + open	Yellow / Green	Flashing in parallel	Damper is moving

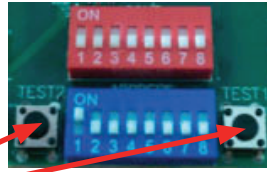

Functionality of Test Buttons

Two test buttons are available in the FSC-UFC24-2 (damper 1 and damper 2). Depending on the application (fire or smoke extraction) the test buttons create different test scenarios. The test scenarios depend on the fire or smoke extraction application.

Fire Application:

- Power on the FSC-UFC24-2: The actuator opens the damper until the end position is reached
- The permanent pushing of the test button will interrupt the power supply to the actuator. Spring is closing the actuator
- As soon as the test button is released the power comes back to the actuator and the damper will open again

Smoke Extraction Application:

- Power on: actuator makes self-test and remains in position defined by controls
- Pushing test button changes command of the actuator – actuator (damper) runs into opposite direction
- Release test button: actuator (damper) runs back into last defined position

If an FSC-UFC24-2 is newly connected to a bus network:

Press one of the test buttons for 5 seconds.

The FSC-UFC24-2 is then recognized and integrated as participant in the bus network. This process can be repeated as often as needed.

Run Time Monitoring of Actuator

The FSC-UFC24-2 is equipped with an actuator run time monitoring function for both actuators independently. This function monitors the time required by the actuator from leaving of the one and reaching of the other end switch. If the actuator does not reach the other end switch in the specified time an error message is sent.

The default value for the actuator run time is 90 seconds. This can be adapted via Modbus or BACnet from 0...360 seconds.

Full Auto Test

The FSC-UFC24-2 offers a 'Full Auto Test' function. This can be controlled through the Modbus or BACnet controller. The command only needs to be sent once to start the function.

Basis of the Functionality

Base for this function is the run time monitoring of the actuator.

Fire Damper

To start the full auto test functionality, the corresponding bus-register has to be activated via bus. By starting the full auto test, the timer of the run time monitoring starts to count the time and the fire damper actuator is closing (spring) and remains in the closed position until the timer of the set running time has reached the set time. Then the actuator will open again automatically until the end switch has been reached. The timer of the run time monitoring starts to count again as soon as the command 'open' has been sent. Once the timer of the set running time has reached the set time, the FSC-UFC24-2 will go back into normal operation mode and a feedback "full auto test ok" is activated. If one of the end switches is not reached within the defined running time, an error message is activated.

Smoke Extraction Damper

To start the full auto test functionality, the corresponding bus-register has to be activated via bus. By starting the full auto test, the timer of the run time monitoring starts to count the time and the smoke extraction damper actuator is moving to the opposite direction and remains in that position until the timer of the set running time has reached the set time. Then the actuator will automatically move back to the original position until the end switch has been reached. The timer of the run time monitoring starts to count again as soon as the command 'opposite direction' has been sent. Once the timer of the set running time has reached the set time, the FSC-UFC24-2 will go back into normal operation mode and a feedback "full auto test ok" is activated. If one of the end switches is not reached within the defined running time, an error message is activated.

Bus Monitoring Application

The FSC-UFC24-2 is equipped with a Bus Monitoring Function. If the bus signal to the FSC-UFC24-2 is interrupted the dampers will move to the safety position after the defined delay and remain there until the bus functionality is back to normal operation.

Objects

There are 2 objects which can be activated by Modbus or BACnet:

- Logic Alarm / Bus Monitoring Function
- Logic Alarm Delay / Set Delay (time in sec)

Default settings:

Logic Alarm / Bus Monitoring Function not active

Activation (via Bus):

- Logic Alarm / Bus Monitoring Function 1 (on)
- Logic Alarm Delay is activated, default delay time is 120 sec. Option to set the delay time via bus between 30...360 sec

Functionality

Fire Damper

After the defined delay the fire damper will move to the closed position and remains closed until the bus functionality is back to normal operation.

Smoke Extraction Damper

If the smoke extraction damper is closed:

After the defined delay the smoke extraction damper will move to the open position and remains open until the bus functionality is back to normal operation.

If the smoke extraction damper is open:

The smoke extraction damper remains in the open position even if the bus signal is interrupted.



Systems & Modules Technology AG
Bachtelstrasse 32
CH-8636 Wald
Switzerland
Phone: +41 55 241 10 20
Mail: info@smtec-ag.ch